

## Super Mini DTOF Principle Lidar

### LD06

LD06 is mainly composed of laser ranging core, wireless transmission unit, wireless communication unit, angle measuring unit, motor driving unit and mechanical housing.

The LD06 ranging core adopts DTOF technology to measure 4500 times each second. When it works, LD06 emits the infrared laser forward, the laser is reflected to the single photon receiving unit after encountering the target object. Thus, we get both time of laser emitting and receiving, the gap between them is time of flight. With the light speed, we can calculate the distance.

After receiving distance data, LD06 will combine them with angel value getting from angle measurement unit to comprise the points cloud data, then transmitting the points cloud data to external interface via wireless communication. Meanwhile the external interface provides PWM to allow motor driving unit to drive the motor. After the external control unit gets the rotational speed, it will reach to specified speed through PID algorithm closed-loop control to ensure LD06 work stably.

### Features

- 12m measuring radius
- 30000lux resistance to strong light
- 4500HZ measurement frequency
- 360°scanning range
- Laser safety FDA Class I
- TOF flight time ranging
- Compact appearance
- Waterproof and dustproof-IPX4
- 10000h service life

### Application Field

- Education
- Scientific research
- Algorithm
- Robot obstacle avoidance
- Autonomous navigation
- Navigation and positioning

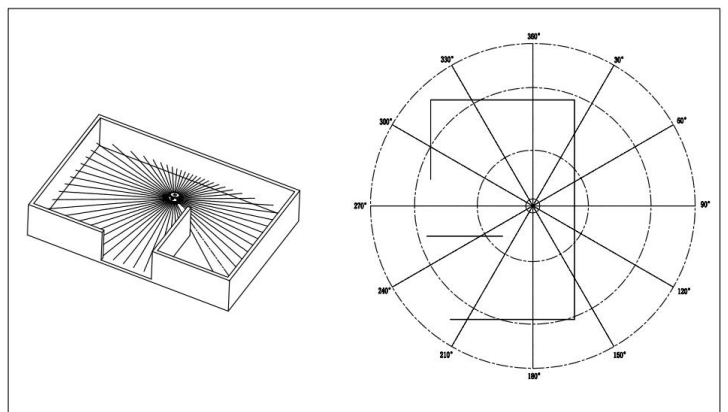
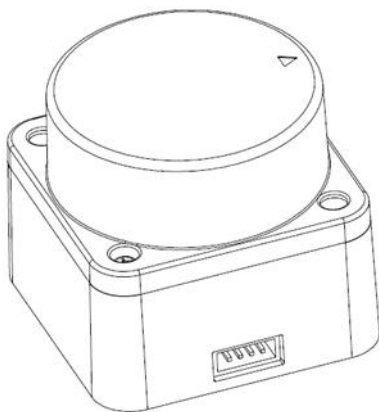

## Contents

|   |   |
|---|---|
| 1. Specifications.....                            | 3 |
| 1.1. Electrical and Mechanical Parameters.....    | 3 |
| 1.2. Optical Parameters.....                      | 3 |
| 1.3. Performance Parameter.....                   | 4 |
| 2. Data Interface.....                            | 4 |
| 2.1. Communication and Interface.....             | 4 |
| 2.2. Scan Data and Coordinate System.....         | 5 |
| 3. Optical Windows and Mechanical Dimensions..... | 5 |
| 4. Safety of Application.....                     | 6 |
| 5. Customized Requirements.....                   | 6 |

## 1. Specifications

### 1.1. Electrical and Mechanical Parameters

| Parameters            | Unit | Minimum                   | Typical | Maximum | Remarks                                    |
|-----------------------|------|---------------------------|---------|---------|--|
| Input Voltage         | V    | 4.5V                      | 5V      | 5.5V    |  |
| PWM Frequency         | KHz  | 20                        | 30      | 50      | Square wave signal                         |
| PWM High Level        | V    | 3.0                       | 3.3     | 5.0     |  |
| PWM Low Level         | V    | 0                         | 0       | 0.5     |  |
| PWM Duty Cycle        | %    | 0                         | 40      | 100     | Scan rate around 10HZ when PWM duty at 40% |
| Start up Current      | mA   | -                         | 300     | -       |  |
| Work Current          | mA   | -                         | 180     | -       |  |
| Size                  | mm   | 38.59*38.59*33.30 (L*W*H) |         |         |  |
| Weight                | g    | -                         | 42      | -       | Without cable                              |
| Interface             | -    | UART @ 230400             |         |         |  |
| UART High Level       | V    | 2.9                       | 3.3     | 3.5     |  |
| UART Low Level        | V    | -0.3                      | 0       | 0.4     |  |
| Drive Motor           | -    | BLDC                      |         |         | Brush-less motor                           |
| Protection Level      |      | IPX-4                     |         |         |  |
| Operating Temperature | °C   | -10                       | 25      | 40      |  |
| Storage Temperature   | °C   | -30                       | 25      | 70      |  |

### 1.2. Optical Parameters

| Parameters            | Unit | Minimum           | Typical | Maximum | Remarks  |
|-----------------------|------|-------------------|---------|---------|--|
| Laser Wave Length     | nm   | 895               | 905     | 915     | Infrared band  |
| Laser Power           | mW   | -                 | 25      | -       | Peak power, the actual average power is much lower than this value |
| Laser Safety Standard | -    | IEC-60825 Class 1 |         |         |  |
| Pitching Angle        | °    | 0                 | 0.5     | 2       |  |

### 1.3. Performance Parameter

| Parameters             | Unit | Minimum | Typical | Maximum | Remarks                    |
|------------------------|------|---------|---------|---------|----------------------------|
| Range                  | m    | 0.02    | -       | 12      | 70%target reflectivity     |
| Scan Frequency         | Hz   | 5       | 10      | 13      | External PWM speed control |
| Sampling Frequency     | Hz   | -       | 4500    | -       | Fixed-Frequency            |
| Ranging Accuracy       | mm   | -       | 30      | 45      |                            |
| Measurement resolution | mm   | -       | 15      | -       |                            |
| Angular Error          | °    | -       | -       | 2       |                            |
| Angular Resolution     | °    | -       | 1       | -       |                            |
| Anti-ambient Light     | KLux | -       | -       | 30      |                            |
| Life Time              | h    | 10000   | -       | -       |                            |

## 2. Data Interface

### 2.1. Communication and Interface

LD06 uses ZH1.5T-4P 1.5mm standard socket to connect with external system for power supply, rotation control and data output. The specific interface definition and parameter requirements are as following:

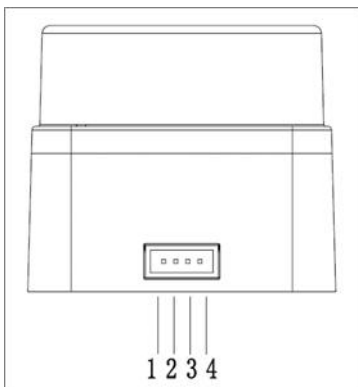

| No | Signal | Type   | Description          | Minimum | Typical | Maximum |
|----|--------|--------|----------------------|---------|---------|---------|
| 1  | Tx     | Output | Radar data output    | 0V      | 3.3V    | 3.5V    |
| 2  | PWM    | Input  | Motor control signal | 0V      | -       | 3.3V    |
| 3  | GND    | Power  | Power negative       | -       | 0V      | -       |
| 4  | P5V    | Power  | Power positive       | 4.5V    | 5V      | 5.5V    |

LD06 has a continuously variable motor driver inside, which can control the start, stop and rotation speed through the PWM signal. Because of the individual differences of each motor driver, the actual speed may be different when the duty cycle is set as a typical value. If need to accurately control the motor speed, you should do closed-loop control via the rotation speed information from the receiving data.

The data communication of LD06 uses standard asynchronous serial port(UART) in one way , and the transmission parameters are shown as below table:

| Baud Rate | Data Bits | Stop Bits | Parity Bit | Flow Control |
|-----------|-----------|-----------|------------|--------------|
| 230400    | 8 Bits    | 1         | No         | No           |

LD06 adopts one-way communication. After working stably, it begins to send measuring data without any instruction.

## 2.2. Coordinate System Definition

LD06 uses the left handed coordinate system, the front side of the sensor is defined as the x-axis (namely the zero direction), the rotation center is the coordinate origin, and the rotation angle increases along the clockwise direction. Please refer to below photo:

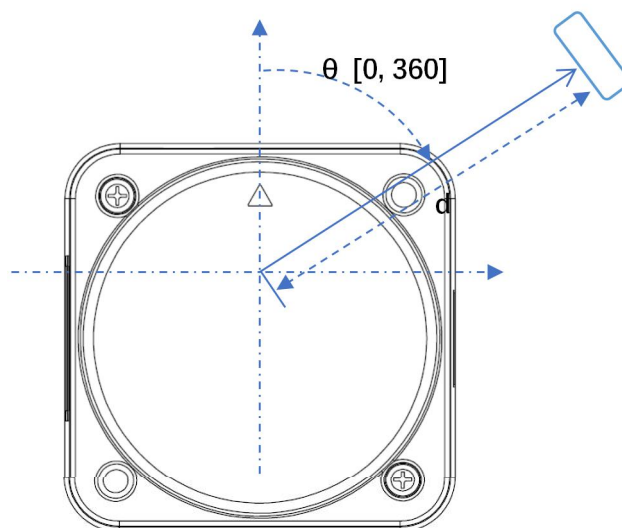

## 3. Optical Windows and Mechanical Dimensions

The laser emitting and receiving of LD06 measuring unit will need an optical window which should be structurally exposed. Any external shield to the window will impact LD06 measuring

performance in some degree.

The following figures show the size of the optical window (unit:mm) .

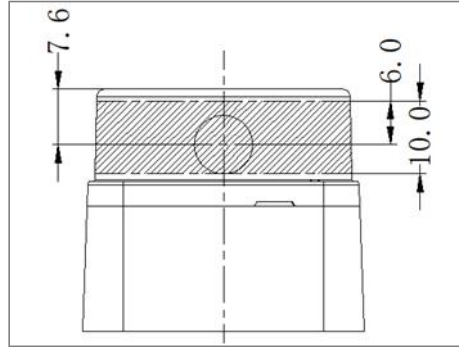

The shaded part in above photo is the optical window. Please do not cover it.

Please refer to below figures for other installation dimensions (unit:mm) :

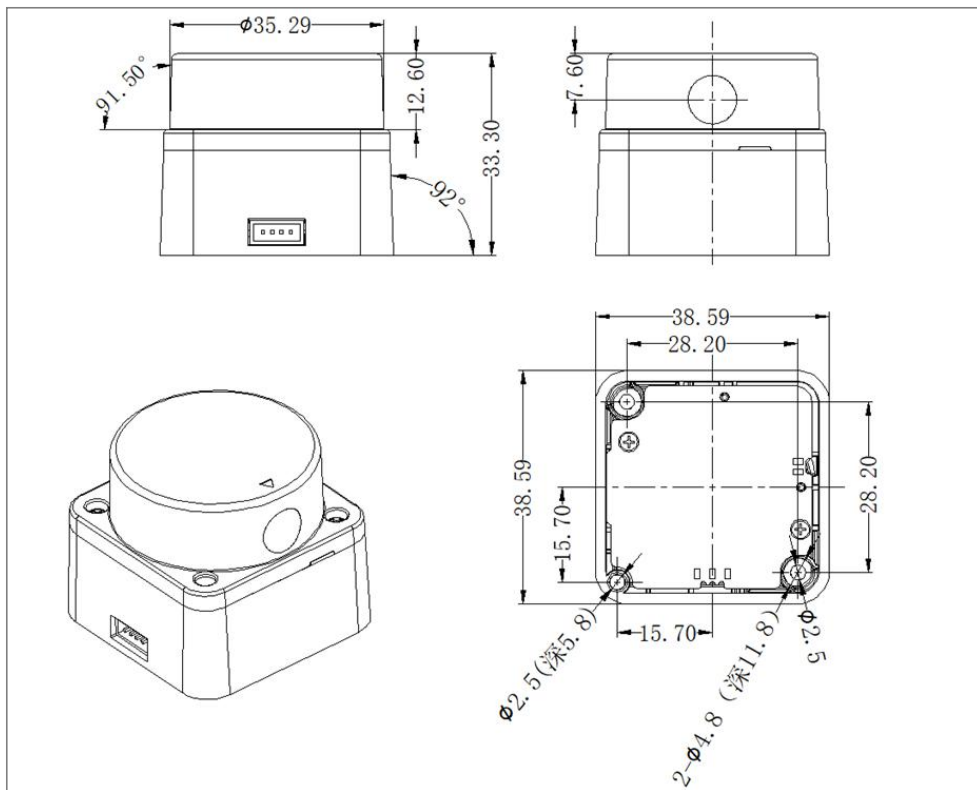

#### 4. Safety and Application Scope

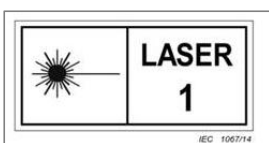

LD06 uses a lower powered infrared laser as emission light source to ensure the safety of human and pets. This Lidar has passed testing and

[www.inno-maker.com](http://www.inno-maker.com) [www.inno-maker.com/wiki](http://www.inno-maker.com/wiki)

Bulk Price: [sales@inno-maker.com](mailto:sales@inno-maker.com)

conformed to Class I, 21 CFR 1040.10 and 1040.11 safety level, except for the deviation of Laser Notice No. 50 of June 24, 2007.

**Caution: The personal adjustment or reassembly of the Lidar may result in hazardous radiation exposure.**

## **5. Customized Requirements**

Its software, hardware parameters and structure can be customized according to customer's demand. If you have any requirement, please contact LDROBOT.